



# CAM

## High-pressure centrifugal fans

### Construction characteristics

- Sheet steel housing.
- Cast aluminium turbine.
- Sheet steel housing. (Mod. 752 y 880)  
Max. airflow temperature: 120°C.
- Asynchronous motors, with squirrel-cage rotor.
  - Standard motors supplied with three-phase 230/400V, 50 Hz up to 5.5 HP, and 400/690V, 50 Hz for more powerful units. Class F electrical insulation.
  - IP-55 protection.
- Corrosion-proof finish in polyester resin, polymerised at 180°C, after degreasing, phosphating and passivation pre-treatment.
- On request:
  - ATEX category 2 certification for explosive atmospheres, CE mark  $\text{C} \llcorner \text{E} \text{X}$  II 2 G/D EEx e or d.
  - Fan capable of a maximum air flow temperature of 250°C.

### Technical characteristics

Model	Velocity (r/min)	Max. admissible current (A)			Installed power (kW)	Max. airflow (m <sup>3</sup> /h)	Sound level pressure dB(A)	Approx. weight Kg.
		230V	400V	690V				
CAM-540-2T	2890	5,63	3,25	-	1,50	2600	85	38
CAM-545-2T-3	2840	7,97	4,60	-	2,20	2630	86	54
CAM-545-2T-4	2880	10,57	6,10	-	3,00	3550	88	64
CAM-550-2T-5,5	2895	13,34	7,70	-	4,00	3500	90	113
CAM-550-2T-7,5	2925	-	10,50	6,10	5,50	4750	91	129
CAM-752-2T-7,5	2920	-	10,50	6,10	5,50	5500	93	138
CAM-752-2T-10	2910	-	13,90	8,00	7,50	6500	94	143
CAM-760-2T-10	2930	-	13,90	8,00	7,50	3400	95	168
CAM-760-2T-15	2940	-	20,00	11,50	11,00	5700	97	196
CAM-760-2T-15/E	2950	-	20,00	11,50	11,00	6800	98	194
CAM-880-2T-40	2950	-	53,00	30,60	30,00	10000	99	390

### Acoustic characteristics

The values shown are calculated using free-field sound pressure levels in dB (A), at a distance equivalent to twice the fan span plus the impeller diameter, with a minimum of 1.5 m.

Sound power spectrum Lw(A) in dB(A) by frequency band in Hz.

Model	63	125	250	500	1000	2000	4000	8000	Model	63	125	250	500	1000	2000	4000	8000
540	57	70	81	90	97	91	86	78	752-10	67	81	92	101	108	102	96	89
545-3	58	71	82	91	98	92	87	79	760-10	70	83	95	103	110	105	99	91
545-4	60	73	84	93	100	94	89	81	760-15	72	85	97	105	112	107	101	93
550-5,5	63	77	88	97	104	98	92	85	760-15/E	73	86	98	106	113	108	102	94
550-7,5	64	78	89	98	105	99	93	86	880	75	89	100	109	116	110	104	97
752-7,5	66	80	91	100	107	101	95	88									





# CAM

## Orientation

Standard LG 270 supply.  
LG 180 position on demand with special fixing measurements.

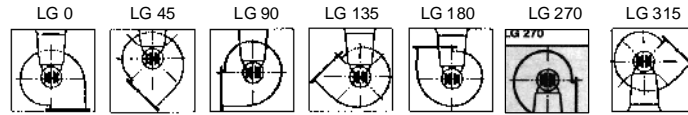

## Dimensions mm

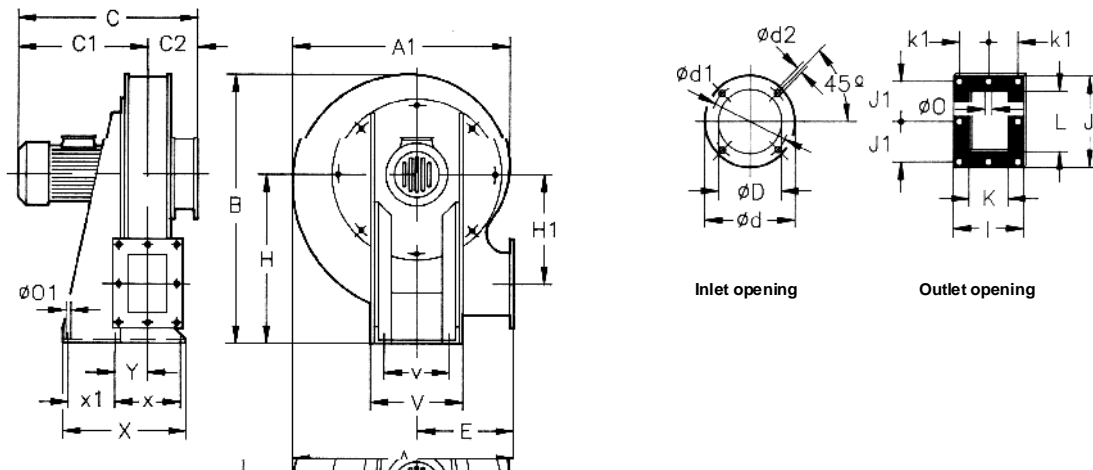

Model	A	A1	B	C	C1	C2	ØD	Ød	Ød1	Ød2	E	H	H1	I	J	J1	K	k1	L	ØO	ØO1	V	v	X	x	x1	Y
CAM-540-2T	565	556	678	424	318	106	170	235	205	11	252	400	270	206	224	92	120	83	140	10	12	280	218	328	186	80	94
CAM-545-2T-3	650	636	768	467	351,5	115,5	165	235	205	11	290	450	310	222	255	108	135	90	170	10	12	300	238	344	202	80	102,5
CAM-545-2T-4	650	636	768	496	380,5	115,5	165	235	205	11	290	450	310	222	255	108	135	90	170	10	12	300	238	344	202	80	102,5

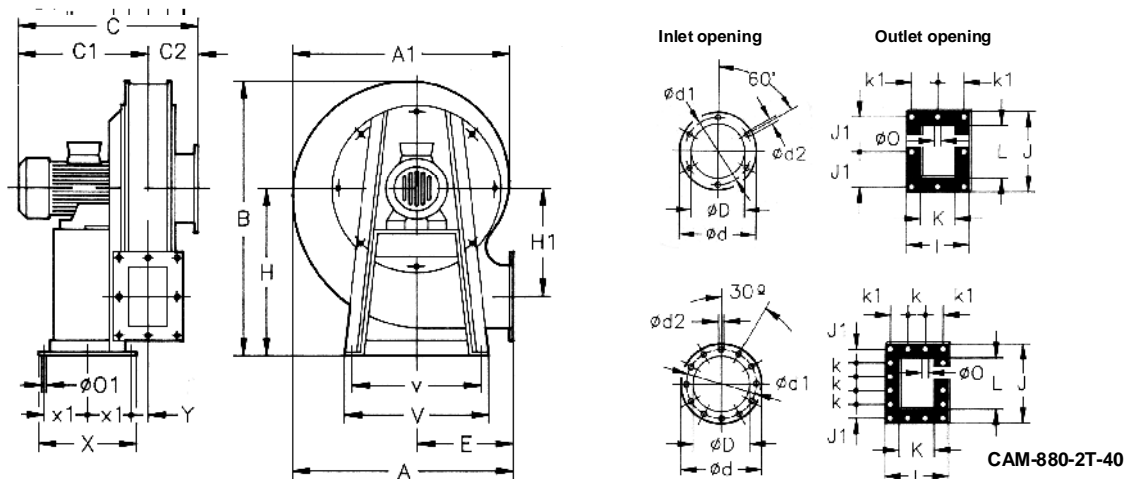

Model	A	A1	B	C	C1	C2	ØD	Ød	Ød1	Ød2	E	H	H1	I	J	J1	K	k	k1	L	ØO	ØO1	V	v	X	x1	Y
CAM-550-2T-5,5	719	715	868	542	406	136	210	278	258	9	311	510	350	246	296	128	150	-	103	200	11	13	475	435	369	105	115,5
CAM-550-2T-7,5	719	715	868	583	447	136	210	278	258	9	311	510	350	246	296	128	150	-	103	200	11	13	475	435	390	105	115,5
CAM-752-2T-7,5	713	713	856	624	489	135	217	278	258	9	315	510	340	256	296	128	160	-	108	200	11	13	475	435	390	105	121
CAM-752-2T-10	713	713	856	624	489	135	217	278	258	9	315	510	340	256	296	128	160	-	108	200	11	13	475	435	390	105	121
CAM-760-2T-10	837,5	833,5	975	609	462	147	246	322	280	9,5	370	570	380	276	316	138	180	-	118	220	11	13	570	525	450	202,5	74,5
CAM-760-2T-15	837,5	833,5	975	715	568	147	246	322	280	9,5	370	570	380	276	316	138	180	-	118	220	11	13	570	525	450	202,5	74,5
CAM-760-2T-15/E	837,5	833,5	975	715	568	147	246	322	280	9,5	370	570	380	276	316	138	180	-	118	220	11	13	570	525	450	202,5	74,5
CAM-880-2T-40	946	941	1046	905	771	134	290	390	355	10	422	710	430	249	360	61	190	71	76	290	11	13	565	523	480	210	133

# CAM

## Characteristics Curves

Q = Airflow in m<sup>3</sup>/h. and m<sup>3</sup>/s.  
 Pe = Static pressure in mm.c.a. and Pa.

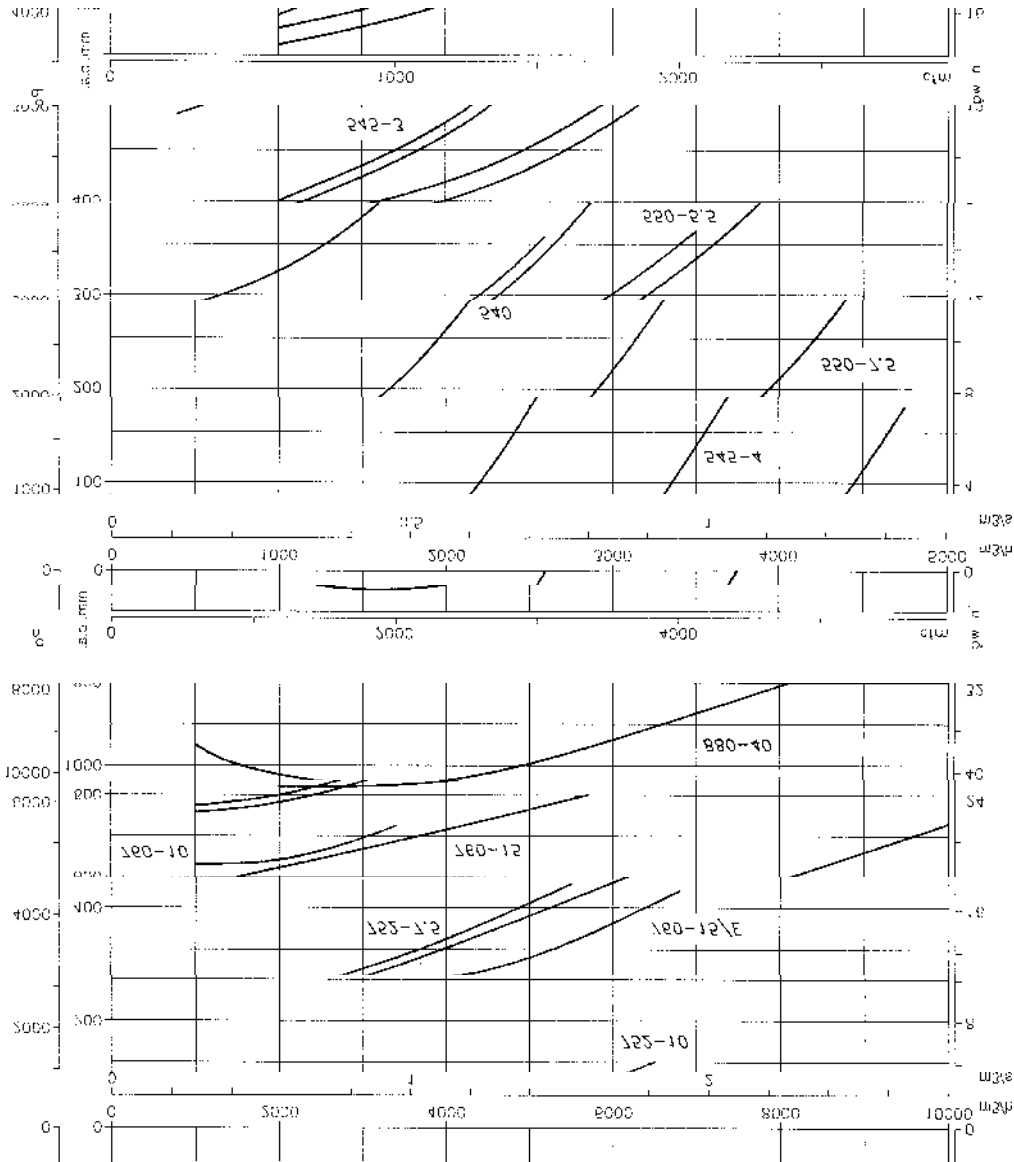

## Accessories

See pages 248 onwards.

