

Difusor DFRE-Q-PR

*Fix blade swirl diffuser with
perforated plate.*

FEI-DFRE-Q-PR-0608-00

Difusor DFRE-Q-PR

Description

The fixed blade swirl diffuser integrated with a perforated plate has been developed for supply and extract applications. The diffuser consists of a fixed perforated plate or hinged for easy access from the diffuser face, with a fixed swirl diffuser on the rear.

The standard plate dimension is 595x595 mm overall which is suitable for 'Lay in' or 'tegular' tile replacement ceilings. It can also be manufactured 599x599 overall to suit 'burgess clip' type ceilings

Application

Increasingly stringent design requirements including higher supply flow rates, lower velocities, thermal gradients in the occupied zone and also the aesthetics (smoother incorporation in the interior design) have generally made swirl diffusers a better choice for air diffusion. This is due to its high induction rate which can reduce velocities, airflow and obtaining better thermal gradient conditions in the occupied zone.

The recommended mounting height is around 2,5 to 3,5 metres, and the distance between the two axes of the diffusers is 2 and 4 metres, this will depend on the air flow of each diffuser.

Standard finish is RAL 9010.

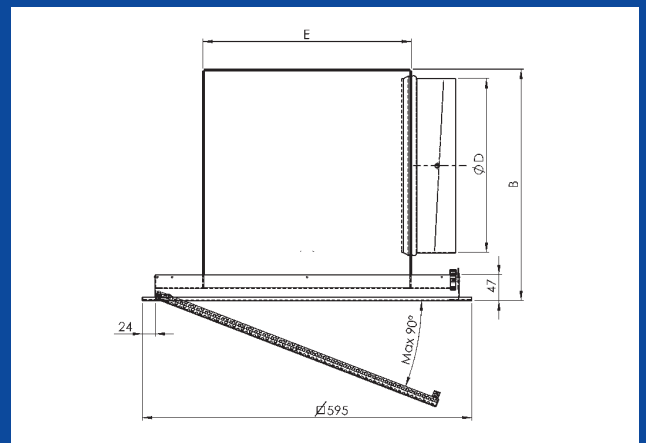
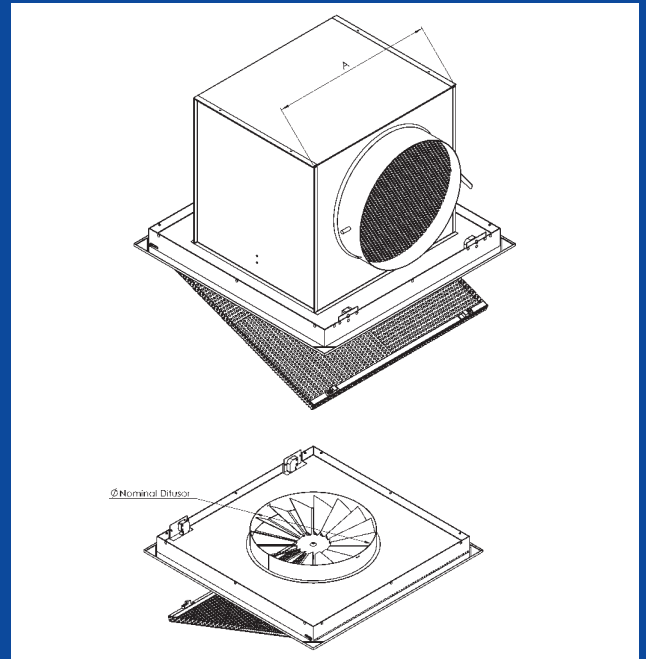

DIMENSIONS

Model	A	B	ØD	E
125	165	195	99	147
160	199	220	124	181
200	239	245	159	221
250	289	275	199	271
315	355	345	249	337
355	394	394	314	376
400	439	394	314	421
500	540	394	314	522

QUICK SELECTION TABLE

AIR FLOW SOUND POWER - PRESSURE DROP - P _t						
Size	m ³ /h (Pa)					
	20 dB(A)	25 dB(A)	30 dB(A)	35 dB(A)	40 dB(A)	45 dB(A)
125	28 (4)	35 (7)	42 (10)	52 (15)	64 (23)	78 (35)
160	54 (4)	66 (8)	80 (11)	98 (17)	119 (25)	145 (36)
200	86 (6)	103 (8)	124 (12)	150 (17)	181 (25)	218 (37)
250	131 (5)	156 (7)	185 (10)	221 (14)	263 (20)	313 (29)
315	238 (5)	285 (8)	340 (11)	406 (16)	485 (23)	580 (32)
355	253 (4)	304 (6)	367 (9)	442 (13)	532 (19)	643 (27)
400	287 (4)	348 (6)	420 (8)	510 (12)	610 (18)	748 (26)
500	437 (5)	518 (7)	615 (9)	730 (13)	866 (19)	1031 (27)